

# EFB START-STOP BATTERY

EFB-D31L(T-110) (12V85Ah)



## CHARACTERISTICS

Item	Specifications	
Nominal Voltage	12V	
Nominal Capacity (20HR)	85Ah	
Reserve Capacity	150min	
Cold Cranking Amps@0°F (-18°C)	760A	
Dimension	Length	303mm (11.9inches)
	Width	170mm (6.69inches)
	Container Height	201mm (7.91inches)
	Total Height (with Terminal)	222mm (8.74inches)
Approx Weight	22.9kg (50.5lbs)	
Terminal	1	
Cell layout	0	
Hold-Down	B1	
Case	Black-PP Material	
Cover	Black-PP Material	
Handle	TS1	

## APPLICATIONS

- Car with start-stop system
- EV/HEV
- Engine start

## GENERAL FEATURES

- High capacity and high CCA
- 2x Faster Charge Acceptance than conventional starter batteries
- 2x Higher Cycle Life than conventional starter batteries
- Strong alloy grids for rugged durability and improved tolerance in extreme temperature conditions
- OE quality certification

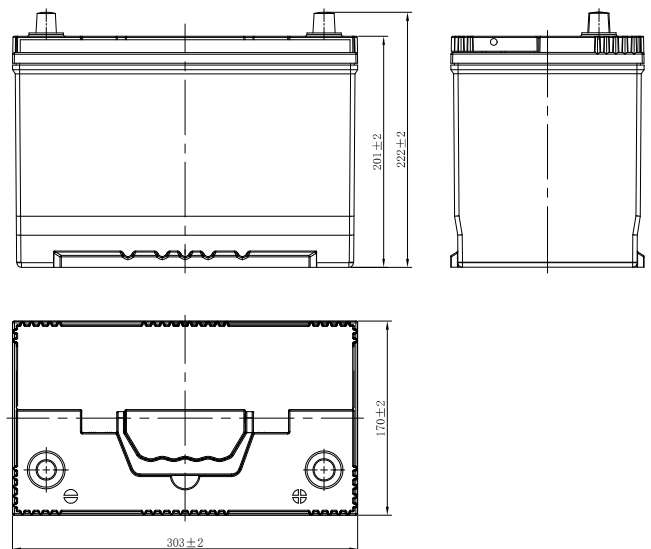
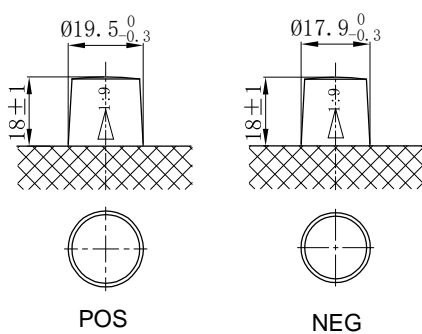

\*Values are subject to variation of +/- 5% in normal manufacturing processes.

Leoch International Technology Ltd.  
[www.leoch.com](http://www.leoch.com)

Leoch Batteries Pte Ltd  
[www.leoch.sg](http://www.leoch.sg)

Leoch Battery Corporation  
[www.leochamericas.com](http://www.leochamericas.com)

Leoch Europe S.A.  
[www.leoch.eu](http://www.leoch.eu)