

EFB START-STOP BATTERY

EFB-Q85L (12V65Ah)



CHARACTERISTICS

Item	Specifications	
Nominal Voltage	12V	
Nominal Capacity (20HR)	65Ah	
Reserve Capacity	118min	
Cold Cranking Amps@0°F (-18°C)	606A	
Dimension	Length	230.5mm (9.07inches)
	Width	171.5mm (6.75inches)
	Container Height	201mm (7.91inches)
	Total Height (with Terminal)	222.5mm (8.76inches)
Approx Weight	17.7kg (39.0lbs)	
Terminal	1	
Cell layout	0	
Hold-Down	B0	
Case	Black-PP Material	
Cover	Black-PP Material	
Handle	NONE	

APPLICATIONS

- Car with start-stop system
- EV/HEV
- Engine start

GENERAL FEATURES

- High capacity and high CCA
- 2x Faster Charge Acceptance than conventional starter batteries
- 2x Higher Cycle Life than conventional starter batteries
- Strong alloy grids for rugged durability and improved tolerance in extreme temperature conditions
- OE quality certification

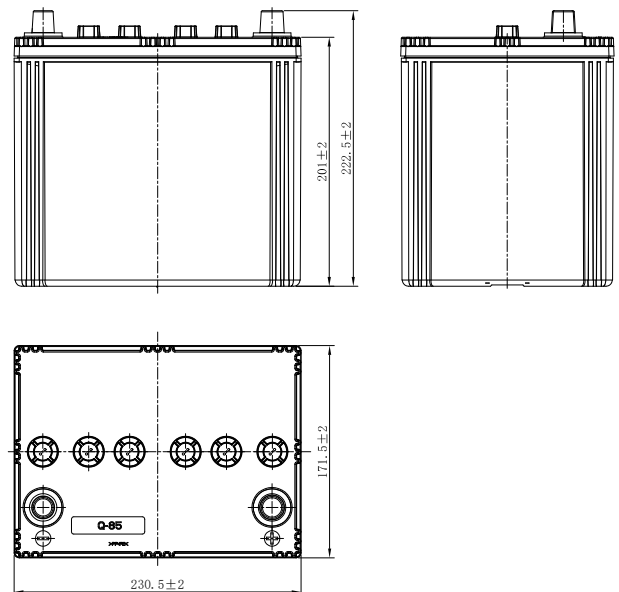
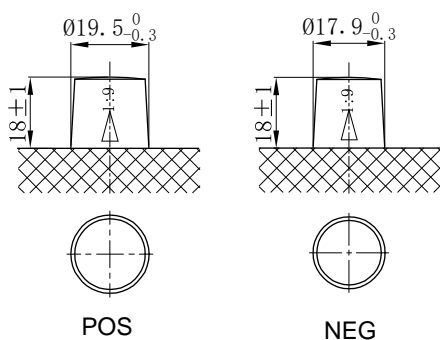

*Values are subject to variation of +/- 5% in normal manufacturing processes.

Leoch International Technology Ltd.
www.leoch.com

Leoch Batteries Pte Ltd
www.leoch.sg

Leoch Battery Corporation
www.leochamericas.com

Leoch Europe S.A.
www.leoch.eu