

# EFB START-STOP BATTERY

EFB-L5 (12V100Ah)



## CHARACTERISTICS

| Item                           | Specifications    |                   |
|--------------------------------|-------------------|-------------------|
| Nominal Voltage                | 12V               |                   |
| Nominal Capacity (20HR)        | 100Ah             |                   |
| Reserve Capacity               | 180min            |                   |
| Cold Cranking Amps@0°F (-18°C) | 800A              |                   |
| Dimension                      | Length            | 351mm(13.8inches) |
|                                | Width             | 174mm(6.85inches) |
|                                | Height            | 188mm(7.40inches) |
| Approx Weight                  | 25kg(55.1lbs)     |                   |
| Terminal                       | 1                 |                   |
| Cell layout                    | 0                 |                   |
| Hold-Down                      | B13               |                   |
| Case                           | Black-PP Material |                   |
| Cover                          | Black-PP Material |                   |
| Handle                         | TS6               |                   |

## APPLICATIONS

- Car with start-stop system
- EV/HEV
- Engine start

## GENERAL FEATURES

- High capacity and high CCA
- 2x Faster Charge Acceptance than conventional starter batteries
- 2x Higher Cycle Life than conventional starter batteries
- Strong alloy grids for rugged durability and improved tolerance in extreme temperature conditions
- OE quality certification

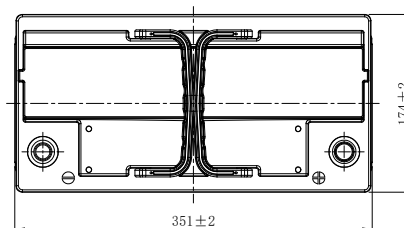
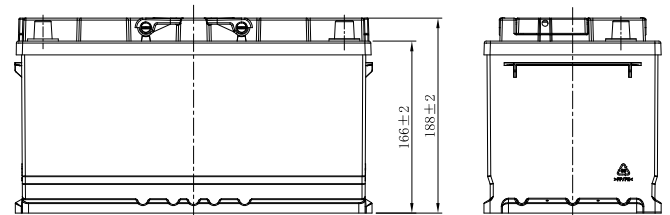
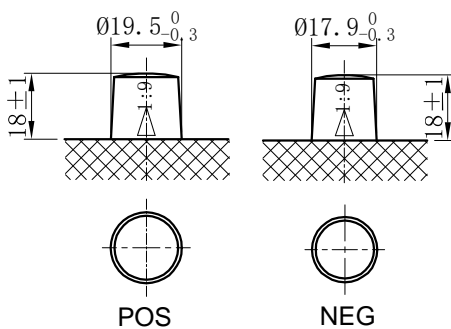

\*Values are subject to variation of +/- 5% in normal manufacturing processes.

Leoch International Technology Ltd.  
www.leoch.com

Leoch Batteries Pte Ltd  
www.leoch.sg

Leoch Battery Corporation  
www.leochamericas.com

Leoch Europe S.A.  
www.leoch.eu

Data above is recommended and the picture is only for battery effect display, Leoch reserve the final right of explanation.  
© LEOCH. All rights reserved. Trademarks and logos are the property of LEOCH and its affiliates unless otherwise noted. Subject to revisions without prior notice. E&OE.

Publication No.: LB-EFB-L5-PD-EN-V1.0-20250220