

# FLOODED HIGH TEMPERATURE BATTERY

155H52LHT (12V165Ah)



## CHARACTERISTICS

Item	Specifications	
Nominal Voltage	12V	
Nominal Capacity (20HR)	165Ah	
Reserve Capacity	324min	
Cold Cranking Amps@0°F (-18°C)	900A	
Dimension	Length	521mm(20.5inches)
	Width	261mm(10.3inches)
	Height	240.5mm(9.47inches)
Approx Weight	50.5kg(111.3lbs)	
Terminal	1	
Cell layout	4	
Hold-Down	B0	
Case	Black-PP Material	
Cover	Black-PP Material	
Handle	TS8	

## APPLICATIONS

- Car start
- EV/HEV
- Engine start

## GENERAL FEATURES

- Design for high temperature countries and regions
- Superior life in high temperature environment
- High tin alloy and thicker positive grid
- High-temp paste
- Patented venting system bring less water loss and prevent acid leakage

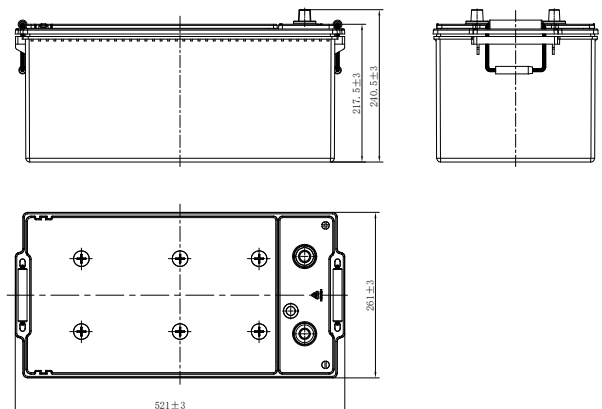
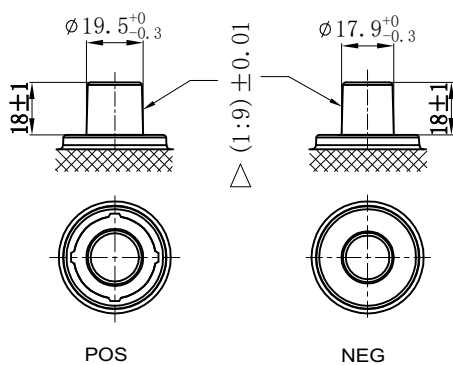

\*Values are subject to variation of +/- 5% in normal manufacturing processes.

Leoch International Technology Ltd.  
www.leoch.com

Leoch Batteries Pte Ltd  
www.leoch.sg

Leoch Battery Corporation  
www.leochamericas.com

Leoch Europe S.A.  
www.leoch.eu

Data above is recommended and the picture is only for battery effect display, Leoch reserve the final right of explanation.  
© LEOCH. All rights reserved. Trademarks and logos are the property of LEOCH and its affiliates unless otherwise noted. Subject to revisions without prior notice. E&OE.

Publication No.: LB-155H52LHT-PD-EN-V1.0-20250220