

HEAVY DUTY FLOODED BATTERY

180H52R (12V190Ah)



CHARACTERISTICS

| Item | Specifications | |
|--------------------------------|-------------------|---------------------|
| Nominal Voltage | 12V | |
| Nominal Capacity (20HR) | 190Ah | |
| Reserve Capacity | 383min | |
| Cold Cranking Amps@0°F (-18°C) | 1050A | |
| Dimension | Length | 521mm(20.5inches) |
| | Width | 261mm(10.3inches) |
| | Height | 240.5mm(9.47inches) |
| Approx Weight | 52.8kg(116.4lbs) | |
| Terminal | 1 | |
| Cell layout | 3 | |
| Hold-Down | B0 | |
| Case | Black-PP Material | |
| Cover | Black-PP Material | |
| Handle | TS8 | |

APPLICATIONS

- Commercial vehicle start
- Engine start

GENERAL FEATURES

- High capacity and high CCA
- Maintenance-free
- High vibration resistance
- Strong lead-calcium alloy grids for great corrosion resistance
- High strength PP case and cover no need be worried about breakage
- OE quality certification

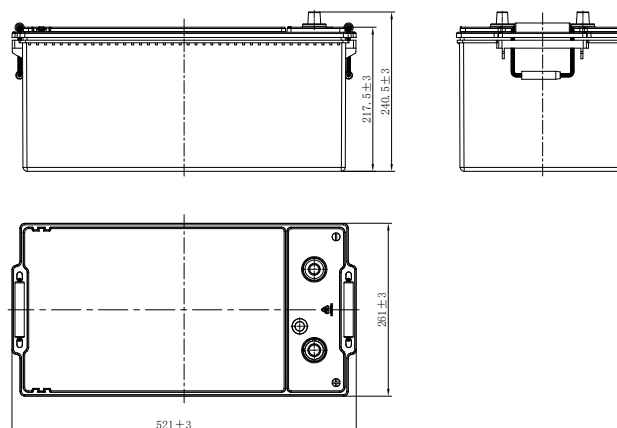
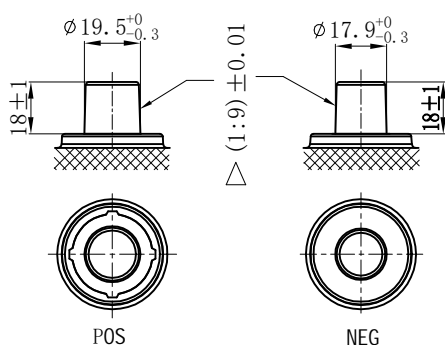

*Values are subject to variation of +/- 5% in normal manufacturing processes.

Leoch International Technology Ltd.

www.leoch.com

Leoch Batteries Pte Ltd

www.leoch.sg

Leoch Battery Corporation

www.leochamericas.com

Leoch Europe S.A.

www.leoch.eu

Data above is recommended and the picture is only for battery effect display, Leoch reserve the final right of explanation.
 © LEOCH. All rights reserved. Trademarks and logos are the property of LEOCH and its affiliates unless otherwise noted. Subject to revisions without prior notice. E&OE.

Publication No.: LB-180H52R-PD-EN-V1.0-20250220