

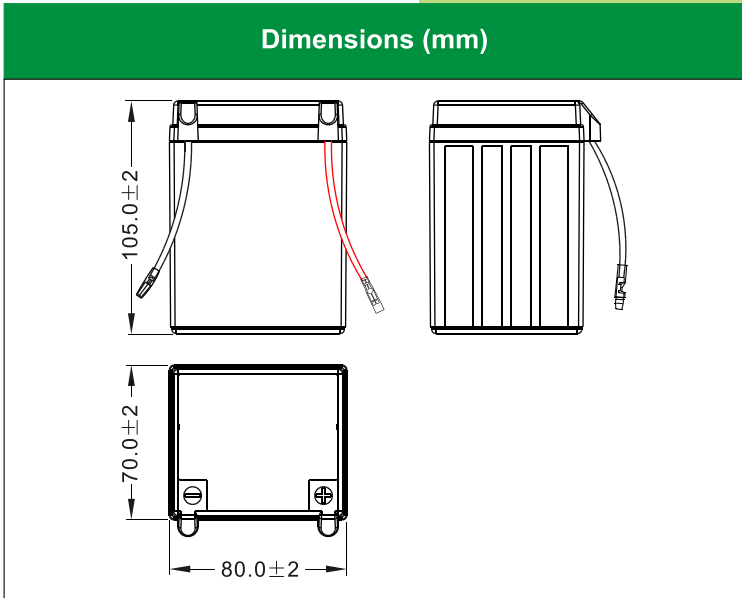

LEOCH BATTERY

LT2.5-3-2 [12V2.5Ah]



Standard Terminal (mm)

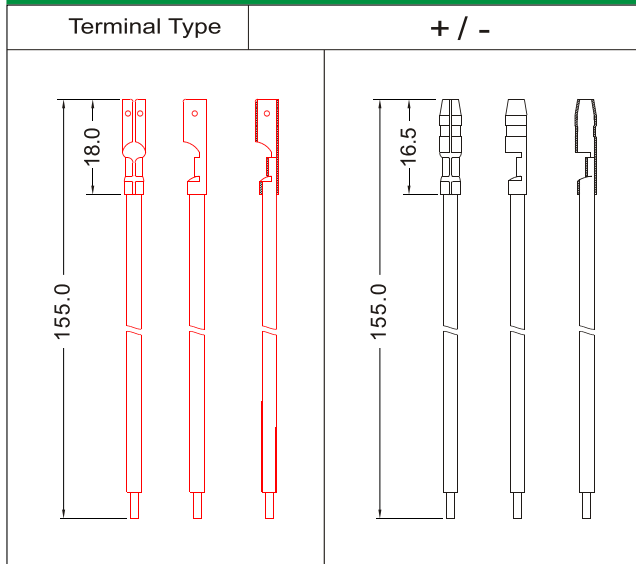

Physical Specification

Nominal Voltage		12V
Nominal Capacity (10HR)		2.5Ah
Dimension	Length	80 ± 2mm (3.15 inches)
	Width	70 ± 2mm (2.76 inches)
	Container Height	105 ± 2mm (4.13 inches)
	Total Height (with Terminal)	105 ± 2mm (4.13 inches)
Weight	Battery(with acid): Approx 1.04kg (2.29lbs)	
	Electrolyte: Approx 0.24kg (0.53lbs)	
<ul style="list-style-type: none"> * Sealed and non-spillable AGM battery * Maintenance-free * Powerful 20 cold cranking amps * Shipped pre-charged and ready to install * Replaces none battery 		

Discharge Characteristics (25°C, 77°F)

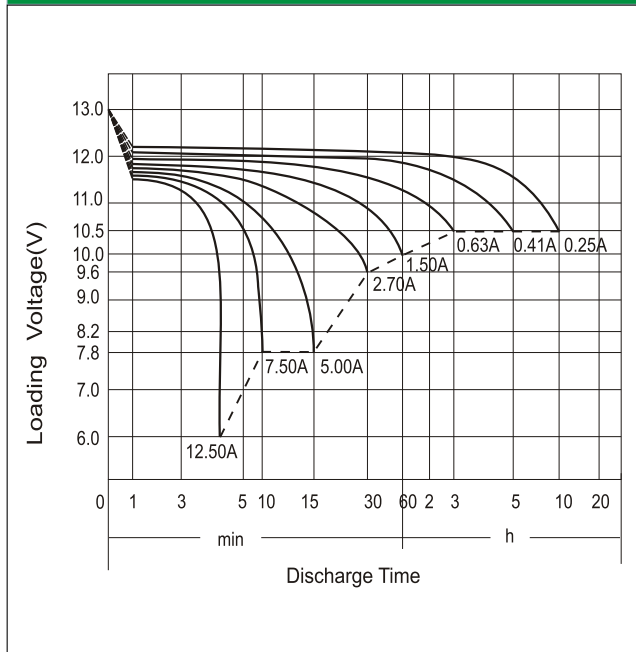

Electrical Specification

Rated Capacity	10 hour rate (0.25 A)		2.50Ah
	5 hour rate (0.41 A)		2.05Ah
	2 hour rate (0.88 A)		1.75Ah
	1 hour rate (1.50 A)		1.50Ah
	0.5 hour rate (2.70 A)		1.35Ah
Capacity affected by Temperature	40 °C (104 °F)		106%
	25 °C (77 °F)		100%
	0 °C (32 °F)		86%
	-15 °C (5 °F)		65%
Charging Methods	Full Charge	Constant-Voltage Charge: Initial charging current: less than 0.75A Voltage: 14.40 V ~ 15.00 V at 25 °C (77 °F) Charging time: 15 ~18h Constant-Current Charge: Charging current: 0.1C ₁₀ =0.25A, when charging voltage up to 14.40V, continue to charge 4h	
	Floating Charge	No limit on Initial charging current Voltage: 13.50 V ~ 13.80 V at 25 °C (77 °F)	